

## Precise and Simple Pallet Weighing

### Rugged, Fast and Easy to Use



#### Ergonomic Full Function Handle

- Easy to Lift
- Easy to Move
- Easy to Weigh



#### Turning Wheel

- Effortless steering
- Easy ride over uneven surfaces



#### Terminal

- Large 7-digit LCD display
- Low power consumption and automatic shut off
- Five standard keys plus two free definable function keys



#### Battery

- 6V DC, 10Ah
- Operating time: 95 hours
- Charging time: 8-12h



#### BTA231 Pallet Truck Scale

### Precise and Simple Pallet Weighing

The mobile battery-powered solution for pallet weighing in one easy step. The BTA231 Pallet Truck Scale is the ideal solution for fast and precise mobile weighing in industrial and warehousing applications.

Technical data

## BTA231 Pallet Truck Scale

### Display

7 digit bright LCD 40mm high

### Capacity

2,000 kg

### Precision

0.1% maximum deviation from measuring range

### Readability (not approved)

1 kg

### Key Pad

6 function tactile keypad

### Battery with Charger

6VDC, 10Ah

95 hours operating time

8~12 hours charging time

### Pallet Truck Construction

Mild steel

### Load Cell Capacity

1 ton x 4, 2mV/V

### Lifting Height

115 mm

### Fork Height

Lowered: 75 mm

Raised: 190 mm

### Fork Length

1,150 mm

### Single Fork Width

180 mm

### Operating Temperature

-10°C to +40°C

<85% humidity

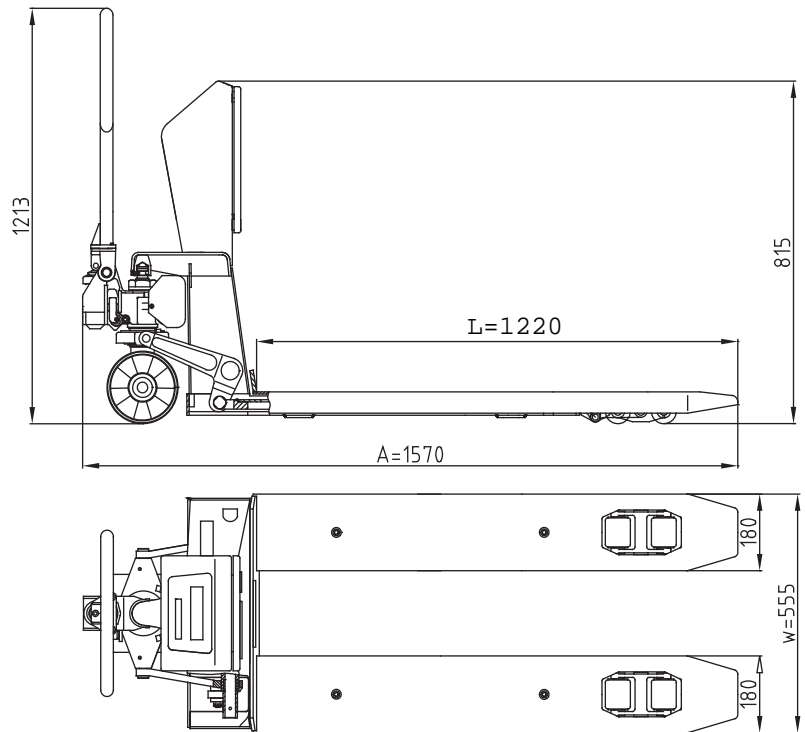

### Pallet Truck Scale

Item	Model	Capacity [t]	Display Resolution [kg]	Fork Size (w x l) [mm]	Length A [mm]	Shipping Information			
						Length[mm]	Width[mm]	Height[mm]	Weight[kg]
30217454	BTA231-555E	2	1	555 x 1220	1570	1720	625	995	200

### Mettler-Toledo AG

CH-8606 Greifensee

Tel. +41-44-944 2211

Fax +41-44-944 3060

Subject to technical changes

© 10/2014 Mettler-Toledo AG

Printed in Switzerland

MTSI 30088262

[www.mt.com/BTA231](http://www.mt.com/BTA231)

For more information